

8:1 Mux-Amps Form Large Multiplane Mux Structures

You can configure a group of analog multiplexers as a large, multi-plane video mux that easily selects multi-channel video sources such as Y-C, R'G'B' and Y'PbPr.

The variety of video sources available to a home video-switching system has grown from a few composite inputs to many multi-signal sources. These include cable, HDTV, satellite STB, VCR, DVD, video games; in broadcast, and multi-PC or graphic KVM (PC) applications. Each requires an NxM:1 multiplexer, in which M is the number of sources and N is the number of channels that make up the signal. As an example, sixteen R', G', B' or Y, Pb, Pr sources require a 3x16:1 multiplexer. Constructing such a multiplexer is difficult, and programming the source selection requires that you combine the individual 16:1 MUX control with the three channels (Table 1).

You can configure a group of analog multiplexers as a large, multi-plane video mux that easily selects multi-channel video sources such as Y-C, R'G'B' and Y'PbPr. The 3x16:1 mux mentioned above is composed of six 8:1 multiplexers (Figure 1) controlled by a 4-bit binary code for source selection. (MAX4315 ICs include a 2V/V fixed-gain output buffer.) The only external circuitry required is half an SN7404 hex inverter for inverting the shutdown signals, and 75 Ω source and load resistors for implementing unity gain when driving a back-terminated load. Substituting a MAX4312 (8-channel video mux with variable-gain output buffer) allows variable gain while rejecting input common-mode voltages.

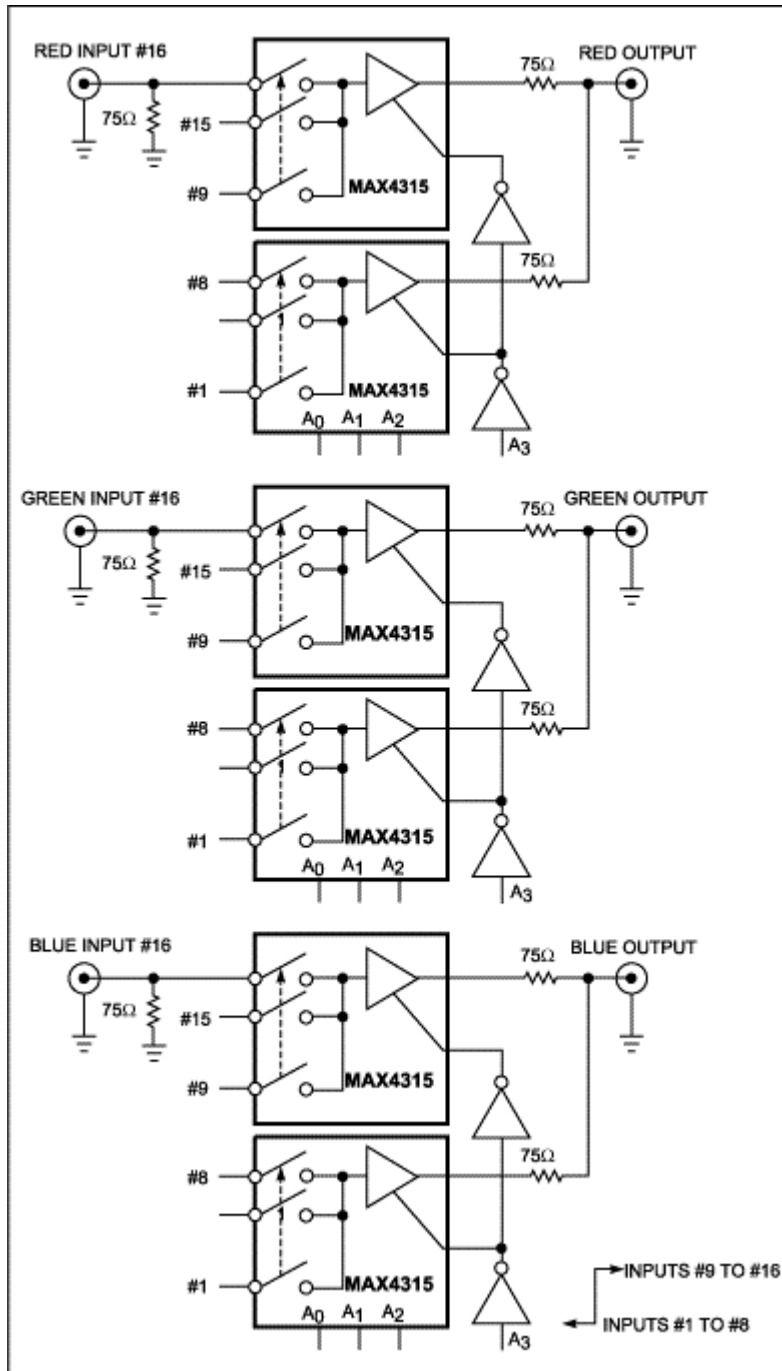

Figure 1. This multi-plane multiplexer selects any one of 16 input signals, each of which consists of the three channels R, G, and B.

The wide bandwidth and high slew rate of these ICs make them ideal for selecting standard video and high-definition broadcast video, as well as graphic sources up to UXGA resolution and above, for KVM applications. No additional buffering is required, because the ICs can drive 150Ω back-terminated coax directly, to within < 0.75V of the supply rails using single or dual supplies. Their fast switching speed (40nsec) and low glitch voltage (10mVp-p) allow, in addition to source selection, insertion of on-screen display (OSD), closed captioning, and tele-text in broadcast and graphics video.

Table 1. Source-Selection Programming

	A0	A1	A2	A3
RGB#1	0	0	0	0
RGB#2	1	0	0	0
RGB#3	0	1	0	0
RGB#4	1	1	0	0
RGB#5	0	0	1	0
RGB#6	1	0	1	0
RGB#7	0	1	1	0
RGB#8	1	1	1	0
RGB#9	0	0	0	1
RGB#10	1	0	0	1
RGB#11	0	1	0	1
RGB#12	1	1	0	1
RGB#13	0	0	1	1
RGB#14	1	0	1	1
RGB#15	0	1	1	1
RGB#16	1	1	1	1

A similar version of this article appeared in the December 26, 2002 issue of *EDN* magazine.

MORE INFORMATION

MAX4312: [QuickView](#) -- [Full \(PDF\) Data Sheet \(440k\)](#) -- [Free Samples](#)

MAX4315: [QuickView](#) -- [Full \(PDF\) Data Sheet \(440k\)](#) -- [Free Sample](#)